

**Caratteristiche Generali giunto elastico flessibile**

- **Montaggio: Orizzontale**
- **Esecuzione: Tipo 1 & tipo DVA**
- **Temperatura d' esercizio: -20°C...+80°C ?**
- **Materiali:**
  - **Mozzi in acciaio**
  - **Elemento elastico in gomma**

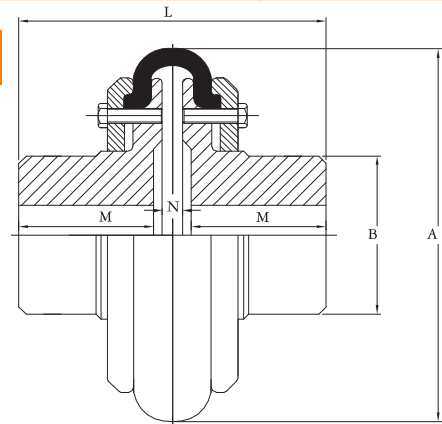

**Grandezze, dimensioni e dati tecnici**

GRANDEZZA	COPPIA NOMINALE [Nm]	COPPIA MAX. [Nm]	VELOCITÀ MAX [1/min]	DIMENSIONI [mm]						MASSA [KG]	INERZIA [Kg·m <sup>2</sup> ]	TORSIONE [°]	COPPIA DI SERRAGGIO [Nm]	TIPO DI GOMMA	
				FORO MIN/MAX	A	B	L	M	N						
<b>SERIE S1</b>	FT-01-1	10	30	4000	8-20	86	30	50	20	8	0,8	-	6	1,5	201
	FT-03-1	20	60	4000	10-22	104	34	64	28	8	1,1	-	8	4	203
	FT-06-1	50	150	4000	10-28	136	48	88	35	8	2,4	0,01	12	6	206
	FT-10-1	100	300	3000	15-38	178	64	125	47	19	5,4	0,05	16	15	210
	FT-14-1	220	660	3000	15-50	210	80	150	59	20	9,3	0,13	21	20	214
	FT-18-1	450	1350	3000	25-60	263	95	174	67	24	17,5	0,42	28	25	218
	FT-22-1	900	2700	2500	35-80	310	115	200	75	20	28	0,90	19	45	222
	FT-25-1	16000	4800	2000	35-100	370	150	215	85	22	50	2,4	18	55	225
	FT-26-1	3000	9000	2000	40-110	402	160	244	95	24	59	3,4	20	60	426
	FT-28-1	5000	15000	1600	55-110	450	160	280	110	40	82	5,7	22	110	828
	FT-30-1	8500	25500	1250	65-120	550	180	360	130	90	140	13,4	25	200	1230
FT-32-1	12500	37500	900	75-180	700	270	450	160	104	327	44	25	240	1832	
<b>SERIE S DVA</b>	FT-1-DVA	25	75	5000	8-22	86	31	60	26	8	0,84	0,001	12	1,5	201
	FT-2-DVA	50	150	5000	10-28	104	40	70	30	8	1,15	0,004	16	4	203
	FT-6-DVA	100	300	5000	10-38	136	55	110	45	8	2,50	0,011	16	6	206
	FT-16-DVA	200	600	4000	15-48	178	70	130	50	19	5,40	0,052	28	15	210
	FT-40-DVA	400	1200	4000	15-65	210	92	160	65	20	9,50	0,14	28	20	214
	FT-63-DVA	800	2400	3000	25-75	263	107	190	75	24	17,5	0,42	28	25	218
	FT-125-DVA	1600	4800	3000	30-100	310	140	240	100	20	30	0,96	26	45	222
	FT-200-DVA	2500	7500	2500	35-100	370	150	345	150	22	71	2,73	18	55	225
	FT-300-DVA	4000	12000	2300	38-110	402	160	364	155	24	82	3,70	20	60	426
	FT-400-DVA	6000	18000	1800	55-120	450	180	440	190	40	122	6,45	22	110	828
	FT-800-DVA	10000	30000	1500	70-140	550	210	520	210	90	185	14,6	25	200	1230
FT-1500-DVA	15000	45000	1000	100-180	700	260	640	255	104	400	46,0	25	240	1832	

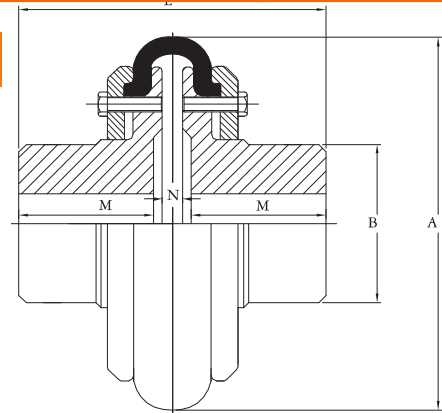

**General Characteristics giunto elastico flessibile**

- **Mounting: Horizonta**
- **Esecutions: Type 1 & type DVA**
- **Exercise temperature: -20°C...+80°C**
- **Materials:**
  - **Steel Hubs**
  - **Tyre elastic element**

**Sizes, dimensions and technical data**

	SIZE	NOMINAL TORQUE [Nm]	MAX. TORQUE [Nm]	MAX SPEED [1/min]	DIMENSIONS[mm]					WEIGHT [KG]	INERTIA [Kg m <sup>2</sup> ]	TORSION [°]	TIGHTENING TORQUE [Nm]	TYRE TYPE	
					BORE MIN/MAX	A	B	L	M						N
<b>SERIE S1</b>	FT-01-1	10	30	4000	8-20	86	30	50	20	8	0,8	-	6	1,5	201
	FT-03-1	20	60	4000	10-22	104	34	64	28	8	1,1	-	8	4	203
	FT-06-1	50	150	4000	10-28	136	48	88	35	8	2,4	0,01	12	6	206
	FT-10-1	100	300	3000	15-38	178	64	125	47	19	5,4	0,05	16	15	210
	FT-14-1	220	660	3000	15-50	210	80	150	59	20	9,3	0,13	21	20	214
	FT-18-1	450	1350	3000	25-60	263	95	174	67	24	17,5	0,42	28	25	218
	FT-22-1	900	2700	2500	35-80	310	115	200	75	20	28	0,90	19	45	222
	FT-25-1	16000	4800	2000	35-100	370	150	215	85	22	50	2,4	18	55	225
	FT-26-1	3000	9000	2000	40-110	402	160	244	95	24	59	3,4	20	60	426
	FT-28-1	5000	15000	1600	55-110	450	160	280	110	40	82	5,7	22	110	828
	FT-30-1	8500	25500	1250	65-120	550	180	360	130	90	140	13,4	25	200	1230
FT-32-1	12500	37500	900	75-180	700	270	450	160	104	327	44	25	240	1832	
<b>SERIE S DVA</b>	FT-1-DVA	25	75	5000	8-22	86	31	60	26	8	0,84	0,001	12	1,5	201
	FT-2-DVA	50	150	5000	10-28	104	40	70	30	8	1,15	0,004	16	4	203
	FT-6-DVA	100	300	5000	10-38	136	55	110	45	8	2,50	0,011	16	6	206
	FT-16-DVA	200	600	4000	15-48	178	70	130	50	19	5,40	0,052	28	15	210
	FT-40-DVA	400	1200	4000	15-65	210	92	160	65	20	9,50	0,14	28	20	214
	FT-63-DVA	800	2400	3000	25-75	263	107	190	75	24	17,5	0,42	28	25	218
	FT-125-DVA	1600	4800	3000	30-100	310	140	240	100	20	30	0,96	26	45	222
	FT-200-DVA	2500	7500	2500	35-100	370	150	345	150	22	71	2,73	18	55	225
	FT-300-DVA	4000	12000	2300	38-110	402	160	364	155	24	82	3,70	20	60	426
	FT-400-DVA	6000	18000	1800	55-120	450	180	440	190	40	122	6,45	22	110	828
	FT-800-DVA	10000	30000	1500	70-140	550	210	520	210	90	185	14,6	25	200	1230
FT-1500-DVA	15000	45000	1000	100-180	700	260	640	255	104	400	46,0	25	240	1832	

