

# HYDRAULIC MOTORS MR

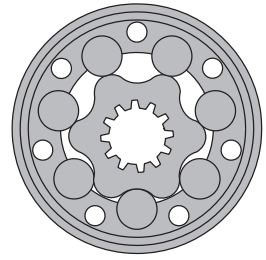

## APPLICATION

- » Conveyors
- » Feeding mechanism of robots and manipulators
- » Metal working machines
- » Textile machines
- » Agricultural machines
- » Food industries
- » Grass cutting machinery etc.



## CONTENTS

Specification data .....29÷30  
 Function diagrams .....31÷39  
 Dimensions and mounting ..... 40÷41  
 Shaft extensions ..... 28  
 Permissible shaft loads ..... 29  
 Permissible shaft Seal Pressure ... 30  
 Order code ..... 42

## OPTIONS

- » Model - Spool valve, roll-gerotor
- » Flange mount
- » Motor with needle bearing
- » Side and rear ports
- » Shafts - straight, splined and tapered
- » Shaft seal for high and low pressure
- » Metric and BSPP ports
- » Speed sensing
- » Other special features

## GENERAL

|   |  |
|---|--|
| <b>Max. Displacement,</b> cm <sup>3</sup> /rev [in <sup>3</sup> /rev] | 397 [24.4]   |
| <b>Max. Speed,</b> [RPM]  | 970  |
| <b>Max. Torque,</b> daNm [lb-in]                                      | cont.: 61 [5400] int.: 69 [6100]                                 |
| <b>Max. Output,</b> kW [HP]   | 15 [20.1]  |
| <b>Max. Pressure Drop,</b> bar [PSI]                                  | cont.: 175 [2540] int.: 200 [2900]                               |
| <b>Max. Oil Flow,</b> lpm [GPM]                                       | 75 [20]  |
| <b>Min. Speed,</b> [RPM]  | 10   |
| <b>Pressure fluid</b>   | Mineral based- HLP(DIN 51524) or HM(ISO 6743/4)                  |
| <b>Temperature range,</b> °C [°F]                                     | -40÷140 [-40÷284]  |
| <b>Optimal Viscosity range,</b> mm <sup>2</sup> /s [SUS]              | 20÷75 [98÷347]   |
| <b>Filtration</b>   | ISO code 20/16 (Min. recommended fluid filtration of 25 microns) |

### Oil flow in drain line

| Pressure drop<br>bar [PSI] | Viscosity<br>mm <sup>2</sup> /s [SUS] | Oil flow in<br>drain line<br>lpm [GPM] |
|----------------------------|---------------------------------------|--|
| 100 [1450]                 | 20 [98]                               | 2,5 [.660]                             |
|                            | 35 [164]                              | 1,8 [.476]                             |
| 140 [2030]                 | 20 [98]                               | 3,5 [.925]                             |
|                            | 35 [164]                              | 2,8 [.740]                             |

### Pressure Losses

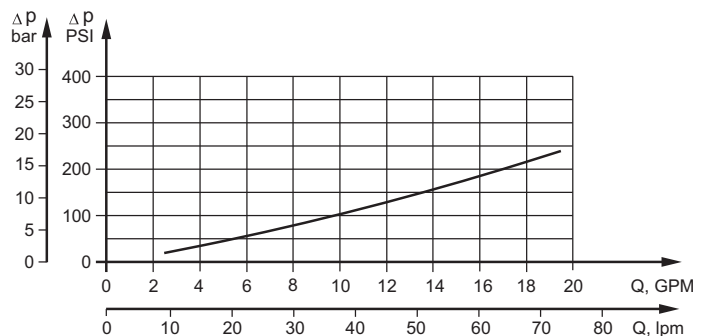

## SPECIFICATION DATA

Specification Data for MR... motors with **C, CO, SH, K** and **SA** shafts.  
(ø28,56 sealing diameter)

| Type   |                             | MR<br>50   | MR<br>80   | MR<br>100  | MR<br>125  | MR<br>160  | MR<br>200  | MR<br>250  | MR<br>315  | MR<br>400  |
|--|-----------------------------|------------|------------|------------|------------|------------|------------|------------|------------|------------|
| Displacement, cm <sup>3</sup> /rev<br>[in <sup>3</sup> /rev] |                             | 51,5       | 80,3       | 99,8       | 125,7      | 159,6      | 199,8      | 250,1      | 315,7      | 397        |
|  |                             | [3.14]     | [4.90]     | [6.09]     | [7.67]     | [9.74]     | [12.19]    | [15.26]    | [19.26]    | [24.4]     |
| Max. Speed,<br>[RPM]   | Cont.                       | 775        | 750        | 600        | 475        | 375        | 300        | 240        | 190        | 150        |
|  | Int.*                       | 970        | 940        | 750        | 600        | 470        | 375        | 300        | 240        | 190        |
| Max. Torque<br>daNm [in-lb]                                  | Cont.                       | 10 [900]   | 20 [1770]  | 24 [2125]  | 30 [2655]  | 39 [3450]  | 38,5[3410] | 39 [3450]  | 36 [3185]  | 38 [3360]  |
|  | Int.*                       | 13 [1150]  | 22 [1947]  | 28 [2480]  | 34 [3010]  | 43 [3805]  | 46 [4070]  | 47 [4160]  | 47 [4160]  | 47 [4160]  |
|  | Peak**                      | 17 [1505]  | 27 [2390]  | 32 [2832]  | 37 [3275]  | 46 [4070]  | 56 [4960]  | 60 [5310]  | 61 [5400]  | 61 [5400]  |
| Max. Output<br>kW [HP]                                       | Cont.                       | 7 [9.5]    | 12,5 [17]  | 13 [17.4]  | 12,5[16.8] | 11,5[15.4] | 9 [12]     | 8 [10.7]   | 5 [6.7]    | 4,8 [6.4]  |
|  | Int.*                       | 8,5 [11.9] | 15 [20.1]  | 15 [20.1]  | 14,5[19.5] | 14 [18.8]  | 12 [16.1]  | 9,5 [12.7] | 8 [10.7]   | 6,8 [9.1]  |
| Max. Pressure Drop<br>bar [PSI]                              | Cont.                       | 140[2030]  | 175[2540]  | 175[2540]  | 175[2540]  | 175[2540]  | 140[2030]  | 110[1600]  | 85 [1230]  | 65 [940]   |
|  | Int.*                       | 175[2540]  | 200[2900]  | 200[2900]  | 200[2900]  | 200[2900]  | 175[2540]  | 140[2030]  | 115[1670]  | 90 [1300]  |
|  | Peak**                      | 225[3260]  | 225[3260]  | 225[3260]  | 225[3260]  | 225[3260]  | 225[3260]  | 200[2900]  | 150[2175]  | 115[1670]  |
| Max. Oil Flow<br>lpm [GPM]                                   | Cont.                       | 40 [10.5]  | 60 [15.8]  | 60 [15.8]  | 60 [15.8]  | 60 [15.8]  | 60 [15.8]  | 60 [15.8]  | 60 [15.8]  | 60 [15.8]  |
|  | Int.*                       | 50 [13.2]  | 75 [19.8]  | 75 [19.8]  | 75 [19.8]  | 75 [19.8]  | 75 [19.8]  | 75 [19.8]  | 75 [19.8]  | 75 [19.8]  |
| Max. Inlet Pressure<br>bar [PSI]                             | Cont.                       | 175[2540]  | 175[2540]  | 175[2540]  | 175[2540]  | 175[2540]  | 175[2540]  | 175[2540]  | 175[2540]  | 175[2540]  |
|  | Int.*                       | 200[2900]  | 200[2900]  | 200[2900]  | 200[2900]  | 200[2900]  | 200[2900]  | 200[2900]  | 200[2900]  | 200[2900]  |
|  | Peak**                      | 225[3260]  | 225[3260]  | 225[3260]  | 225[3260]  | 225[3260]  | 225[3260]  | 225[3260]  | 225[3260]  | 225[3260]  |
| Max. Return Pres-<br>sure with Drain Line<br>bar [PSI]       | Cont.                       | 175[2540]  | 175[2540]  | 175[2540]  | 175[2540]  | 175[2540]  | 175[2540]  | 175[2540]  | 175[2540]  | 175[2540]  |
|  | Int.*                       | 200[2900]  | 200[2900]  | 200[2900]  | 200[2900]  | 200[2900]  | 200[2900]  | 200[2900]  | 200[2900]  | 200[2900]  |
|  | Peak**                      | 225[3260]  | 225[3260]  | 225[3260]  | 225[3260]  | 225[3260]  | 225[3260]  | 225[3260]  | 225[3260]  | 225[3260]  |
| Max. Starting Pressure with<br>Unloaded Shaft, bar [PSI]     |                             | 10 [145]   | 10 [145]   | 10 [145]   | 9 [130]    | 7 [102]    | 5 [73]     | 4 [58]     | 3 [44]     | 3 [44]     |
| Min. Starting Torque<br>daNm [in-lb]                         | At max.press.<br>drop Cont. | 8 [710]    | 15 [1330]  | 20 [1770]  | 25 [2215]  | 32 [2832]  | 33 [2920]  | 31 [2740]  | 31,5[2875] | 31,5[2875] |
|  | At max.press.<br>drop Int.* | 10 [85]    | 17 [1505]  | 23 [2035]  | 28 [2480]  | 37 [3275]  | 40 [3540]  | 48 [4250]  | 58 [5220]  | 50 [4425]  |
|  |                             |            |            |            |            |            |            |            |            |            |
| Min. Speed***, [RPM]   |                             | 10         | 10         | 10         | 10         | 10         | 10         | 10         | 10         | 10         |
| Weight, kg [lb]  | MR(F)                       | 6,8 [15]   | 6,9 [15,2] | 7,2 [15.9] | 7,3 [16.1] | 7,5 [15.2] | 8 [17.6]   | 8,4 [18.5] | 9,1 [20]   | 9,8 [21.6] |
|  | MRQ(N)                      | 6,2 [13.7] | 6,3 [13.9] | 6,6 [14.6] | 6,8 [15]   | 7,2 [14.7] | 7,6 [15.4] | 7,8 [17.2] | 8,6 [19]   | 9,3 [20.5] |
| For rear ports: +0,650 [1.433]                               |                             |            |            |            |            |            |            |            |            |            |

\* Intermittent operation: the permissible values may occur for max. 10% of every minute.

\*\* Peak load: the permissible values may occur for max. 1% of every minute.

\*\*\* For speeds lower than given, consult factory or your regional manager.

1. Intermittent speed and intermittent pressure must not occur simultaneously.
2. Recommended filtration is per ISO cleanliness code 20/16. A nominal filtration of 25 micron or better.
3. Recommend using a premium quality, anti-wear type mineral based hydraulic oil HLP(DIN51524) or HM ( ISO 6743/4).  
If using synthetic fluids consult the factory for alternative seal materials.
4. Recommended minimum oil viscosity 13 mm<sup>2</sup>/s [70 SUS] at 50°C [122°F].
5. Recommended maximum system operating temperature is 82°C [180°F].
6. To assure optimum motor life fill with fluid prior to loading and run at moderate load and speed for 10-15 minutes.

## SPECIFICATION DATA (continued)

Specification Data for MR... motors with CB, KB, OB and HB shafts.  
(ø35 sealing diameter)

| Type  |                             | MR<br>50   | MR<br>80  | MR<br>100  | MR<br>125  | MR<br>160  | MR<br>200  | MR<br>250  | MR<br>315  | MR<br>400  |
|---|-----------------------------|------------|-----------|------------|------------|------------|------------|------------|------------|------------|
| Displacement, cm <sup>3</sup> /rev<br>[in <sup>3</sup> /rev ] |                             | 51,5       | 80,3      | 99,8       | 125,7      | 159,6      | 199,8      | 250,1      | 315,7      | 397        |
|   |                             | [3.14]     | [4.90]    | [6.09]     | [7.67]     | [9.74]     | [12.19]    | [15.26]    | [19.26]    | [24.4]     |
| Max. Speed,<br>[RPM]  | Cont.                       | 775        | 750       | 600        | 475        | 375        | 300        | 240        | 190        | 150        |
|   | Int.*                       | 970        | 940       | 750        | 600        | 470        | 375        | 300        | 240        | 190        |
| Max. Torque<br>daNm [in-lb]                                   | Cont.                       | 10 [900]   | 20 [1770] | 24 [2125]  | 30 [2655]  | 39 [3450]  | 45 [4000]  | 54 [4780]  | 55 [4870]  | 61 [5400]  |
|   | Int.*                       | 13 [1150]  | 22 [1947] | 28 [2480]  | 34 [3010]  | 43 [3805]  | 50 [4425]  | 61 [5400]  | 69 [6110]  | 69 [6110]  |
|   | Peak**                      | 17 [1505]  | 27 [2390] | 32 [2832]  | 37 [3275]  | 46 [4070]  | 56 [4960]  | 71 [6280]  | 84 [7435]  | 87 [7700]  |
| Max. Output<br>kW [HP]  | Cont.                       | 7 [9.5]    | 12,5 [17] | 13 [17.4]  | 12,5[16.8] | 11,5[15.4] | 11 [14.8]  | 10 [13.4]  | 9 [12]     | 7,8 [10.5] |
|   | Int.*                       | 8,5 [11.9] | 15 [20.1] | 15 [20.1]  | 14,5[19.5] | 14 [18.8]  | 13 [17.4]  | 12 [16.1]  | 10 [13.4]  | 10,6[14.2] |
| Max. Pressure Drop<br>bar [PSI]                               | Cont.                       | 140[2030]  | 175[2540] | 175[2540]  | 175[2540]  | 175[2540]  | 175[2540]  | 175[2540]  | 135[1960]  | 110[1600]  |
|   | Int.*                       | 175[2540]  | 200[2900] | 200[2900]  | 200[2900]  | 200[2900]  | 200[2900]  | 200[2900]  | 175 [2540] | 140[2030]  |
|   | Peak**                      | 225[3260]  | 225[3260] | 225 [3260] | 225[3260]  | 225[3260]  | 225[3260]  | 225[3260]  | 210[3045]  | 175[2540]  |
| Max. Oil Flow<br>lpm [GPM]                                    | Cont.                       | 40 [10.5]  | 60 [15.8] | 60 [15.8]  | 60 [15.8]  | 60 [15.8]  | 60 [15.8]  | 60 [15.8]  | 60 [15.8]  | 60 [15.8]  |
|   | Int.*                       | 50 [13.2]  | 75 [19.8] | 75 [19.8]  | 75 [19.8]  | 75 [19.8]  | 75 [19.8]  | 75 [19.8]  | 75 [19.8]  | 75 [19.8]  |
| Max. Inlet Pressure<br>bar [PSI]                              | Cont.                       | 175[2540]  | 175[2540] | 175[2540]  | 175[2540]  | 175[2540]  | 175[2540]  | 175[2540]  | 175[2540]  | 175[2540]  |
|   | Int.*                       | 200[2900]  | 200[2900] | 200[2900]  | 200[2900]  | 200[2900]  | 200[2900]  | 200[2900]  | 200[2900]  | 200[2900]  |
|   | Peak**                      | 225[3260]  | 225[3260] | 225 [3260] | 225[3260]  | 225[3260]  | 225[3260]  | 225[3260]  | 225[3260]  | 225[3260]  |
| Max. Return Pres-<br>sure with Drain Line<br>bar [PSI]        | Cont.                       | 175[2540]  | 175[2540] | 175[2540]  | 175[2540]  | 175[2540]  | 175[2540]  | 175[2540]  | 175[2540]  | 175[2540]  |
|   | Int.*                       | 200[2900]  | 200[2900] | 200[2900]  | 200[2900]  | 200[2900]  | 200[2900]  | 200[2900]  | 200[2900]  | 200[2900]  |
|   | Peak**                      | 225[3260]  | 225[3260] | 225 [3260] | 225[3260]  | 225[3260]  | 225[3260]  | 225[3260]  | 225[3260]  | 225[3260]  |
| Max. Starting Pressure with<br>Unloaded Shaft, bar [PSI]      |                             | 10 [145]   | 10 [145]  | 10 [145]   | 9 [130]    | 7 [102]    | 5 [73]     | 4 [58]     | 3 [44]     | 3 [44]     |
| Min. Starting Torque<br>daNm [in-lb]                          | At max.press.               |            |           |            |            |            |            |            |            |            |
|   | drop Cont.                  | 8 [710]    | 15 [1330] | 20 [1770]  | 25 [2215]  | 32 [2832]  | 41 [3630]  | 50 [4425]  | 50 [4425]  | 50 [4425]  |
|   | At max.press.<br>drop Int.* | 10 [885]   | 17 [1505] | 23 [2035]  | 28 [2480]  | 37 [3275]  | 46 [4070]  | 55 [4870]  | 66 [5840]  | 61 [5400]  |
| Min. Speed***, [RPM]  |                             | 10         | 10        | 10         | 10         | 10         | 10         | 10         | 10         | 10         |
| Weight, kg [lb]   |                             |            |           |            |            |            |            |            |            |            |
| For rear ports: +0,650 [1.433]                                |                             | 6,9 [15,2] | 7 [15,4]  | 7,3 [16.1] | 7,4 [16.3] | 7,6 [15.4] | 8,1 [18.9] | 8,5 [18.7] | 9,2 [20.3] | 9,9 [21.8] |

\* Intermittent operation: the permissible values may occur for max. 10% of every minute.

\*\* Peak load: the permissible values may occur for max. 1% of every minute.

\*\*\* For speeds lower than given, consult factory or your regional manager.

- Intermittent speed and intermittent pressure must not occur simultaneously.
- Recommended filtration is per ISO cleanliness code 20/16. A nominal filtration of 25 micron or better.
- Recommend using a premium quality, anti-wear type mineral based hydraulic oil HLP(DIN51524) or HM ( ISO 6743/4).  
If using synthetic fluids consult the factory for alternative seal materials.
- Recommended minimum oil viscosity 13 mm<sup>2</sup>/s [70 SUS] at 50°C [122°F].
- Recommended maximum system operating temperature is 82°C [180°F].
- To assure optimum motor life fill with fluid prior to loading and run at moderate load and speed for 10-15 minutes.

**FUNCTION DIAGRAMS**

**MR 50**

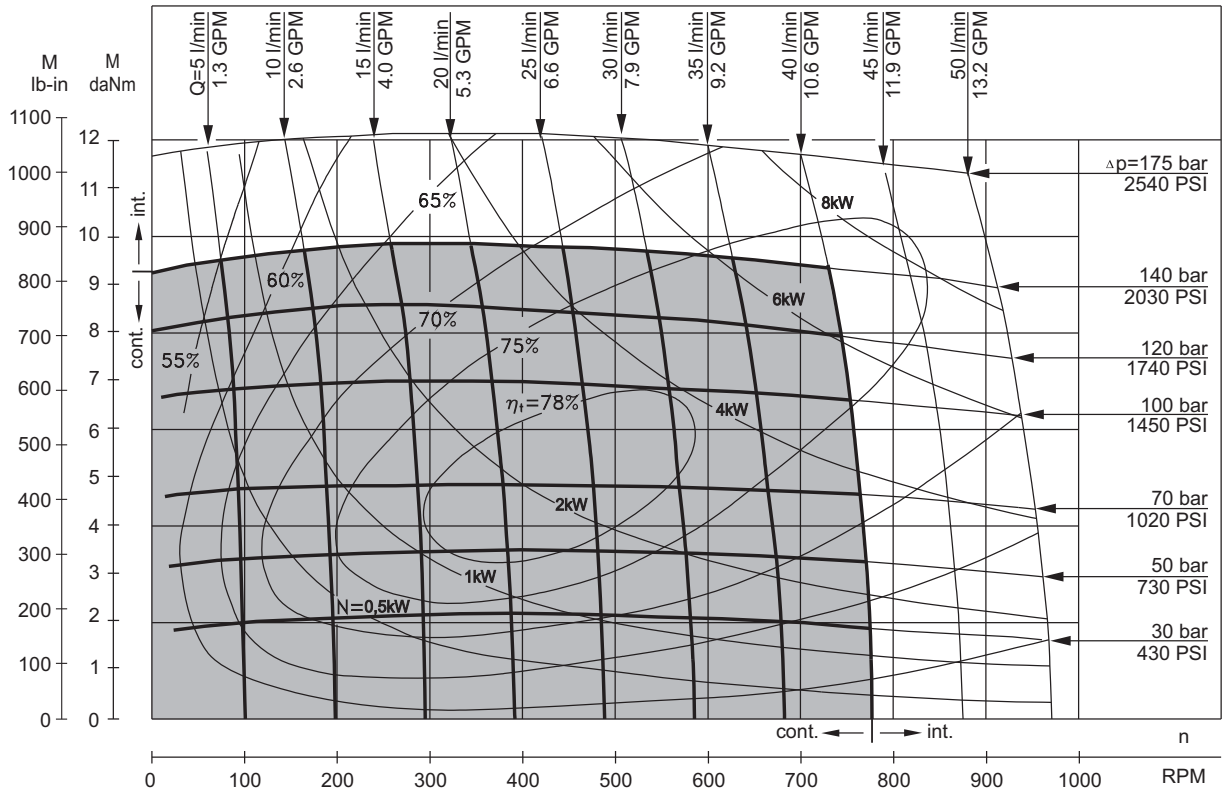

**MR 80**

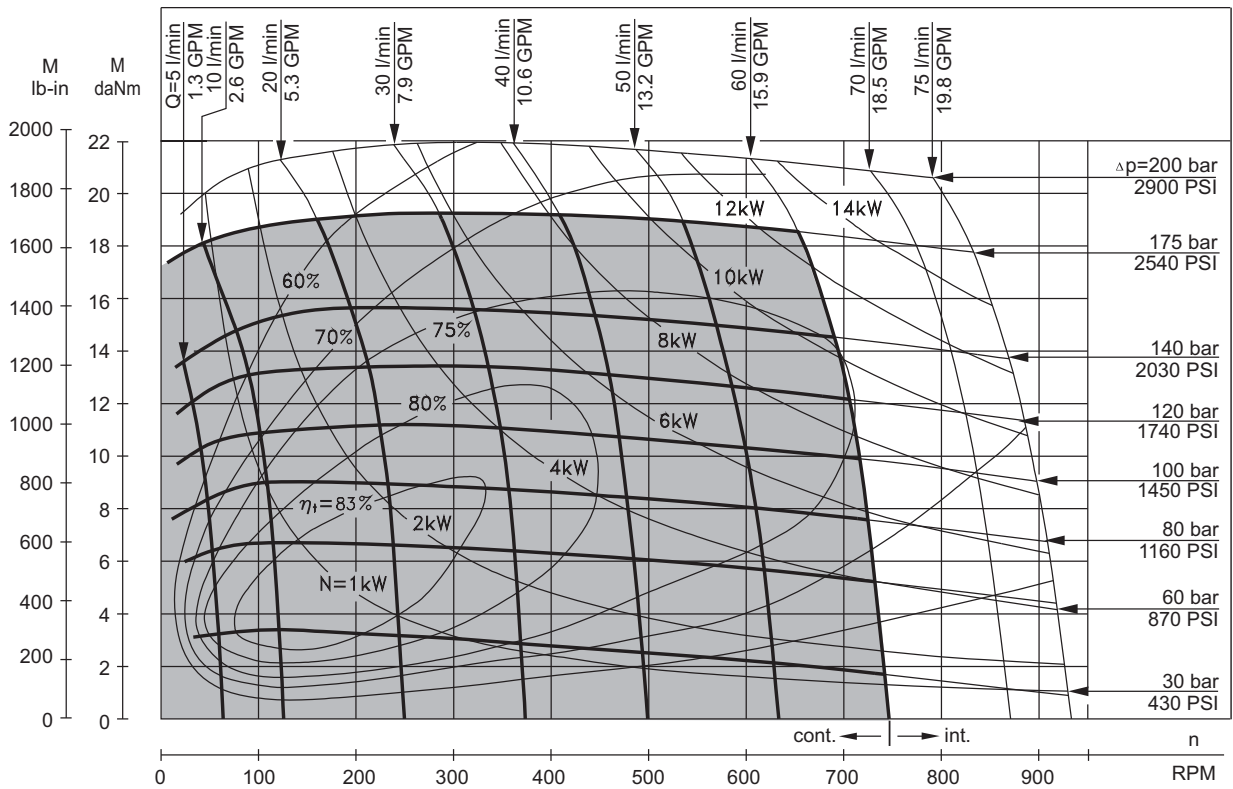

The function diagrams data is for average performance of randomly selected motors at back pressure  $5 \pm 10$  bar [72.5±145 PSI] and oil with viscosity of 32 mm<sup>2</sup>/s [150 SUS] at 50°C [122°F].

**FUNCTION DIAGRAMS**

**MR 100**

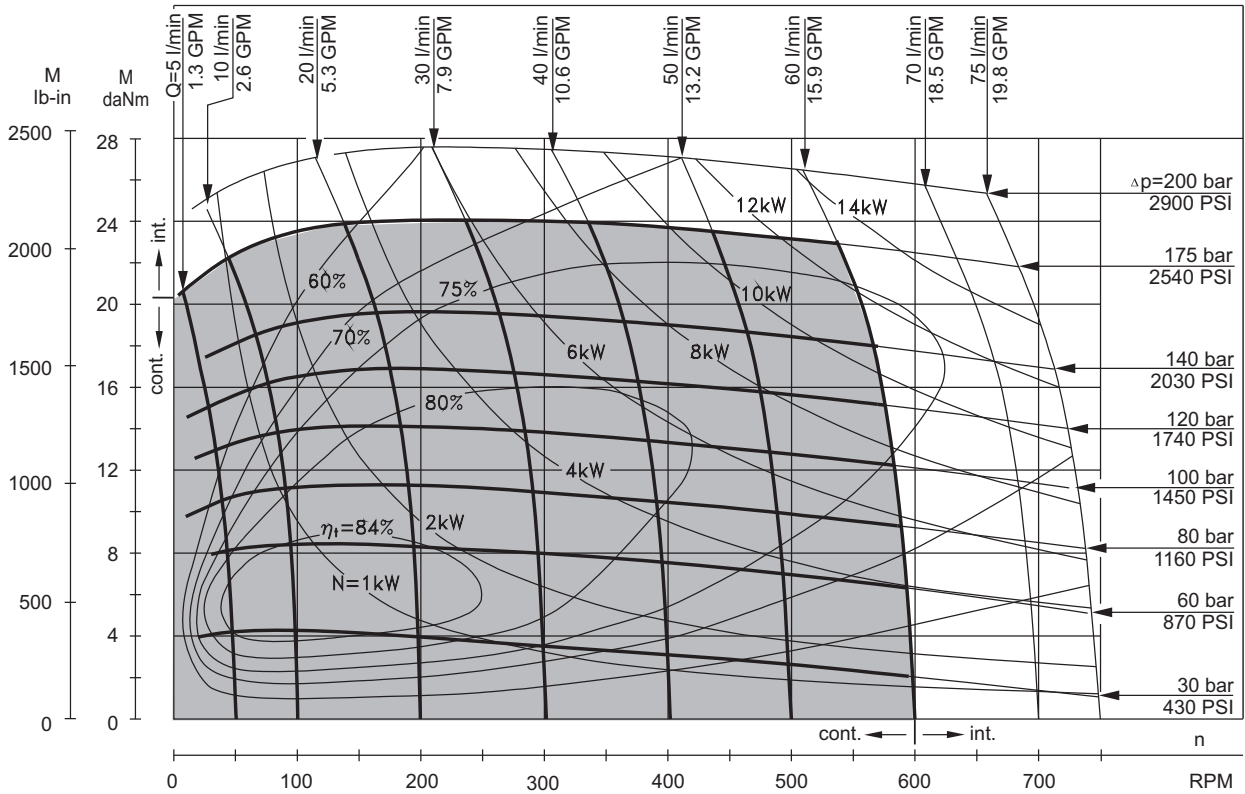

**MR 125**

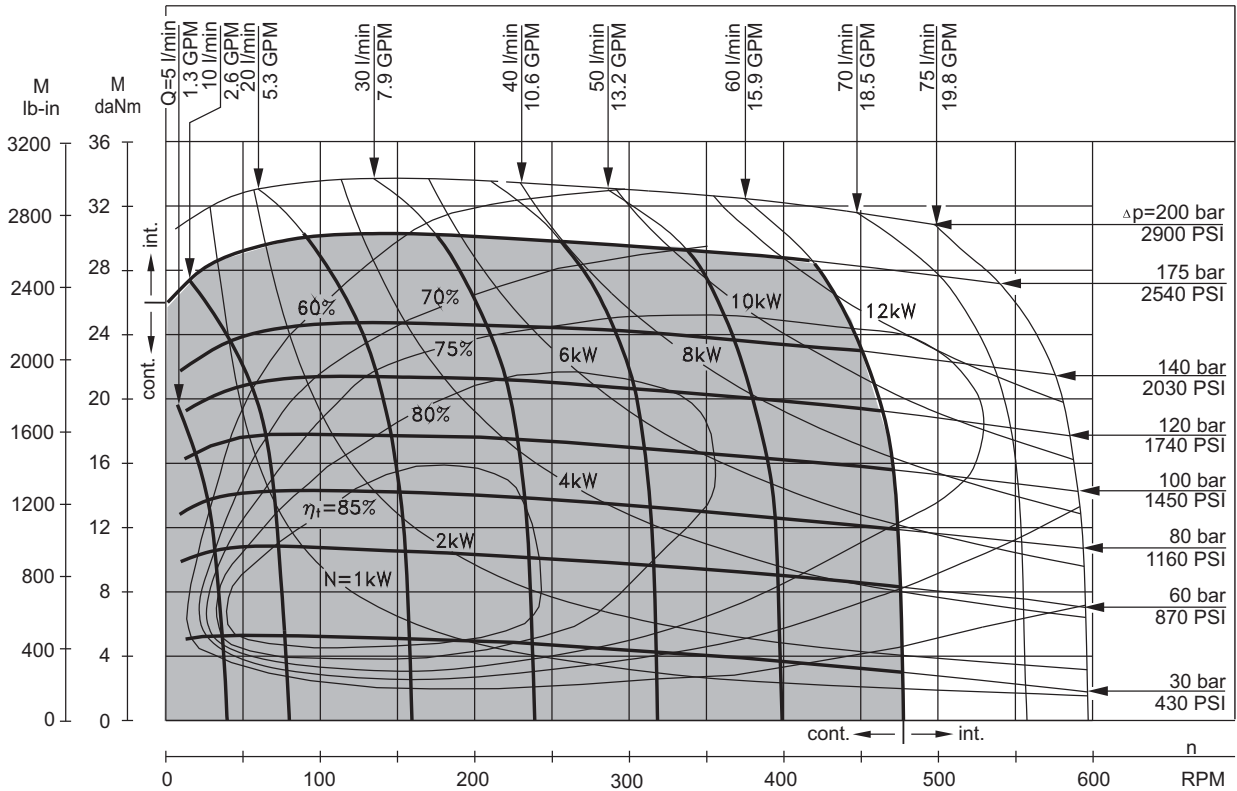

The function diagrams data is for average performance of randomly selected motors at back pressure  $5 \pm 10$  bar [72.5±145 PSI] and oil with viscosity of 32 mm<sup>2</sup>/s [150 SUS] at 50°C [122°F].

**FUNCTION DIAGRAMS**

**MR 160**

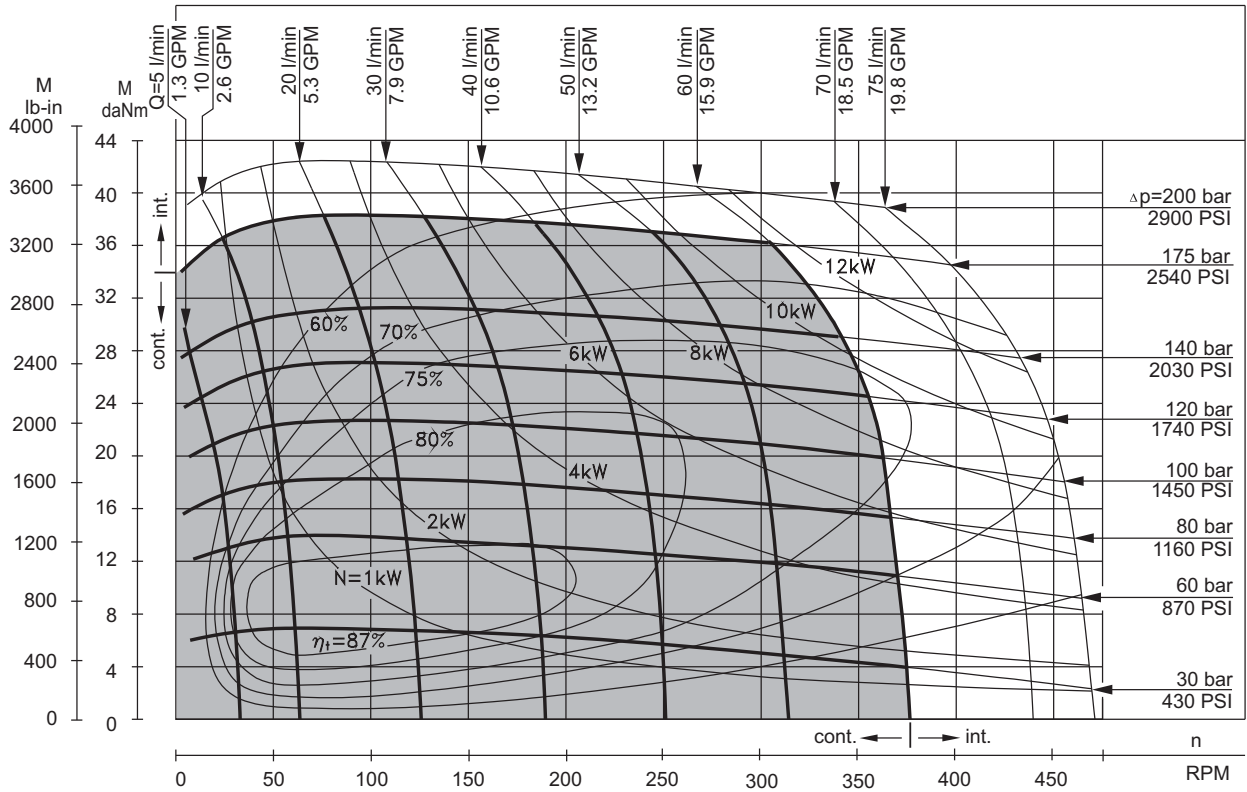

**MR 200**

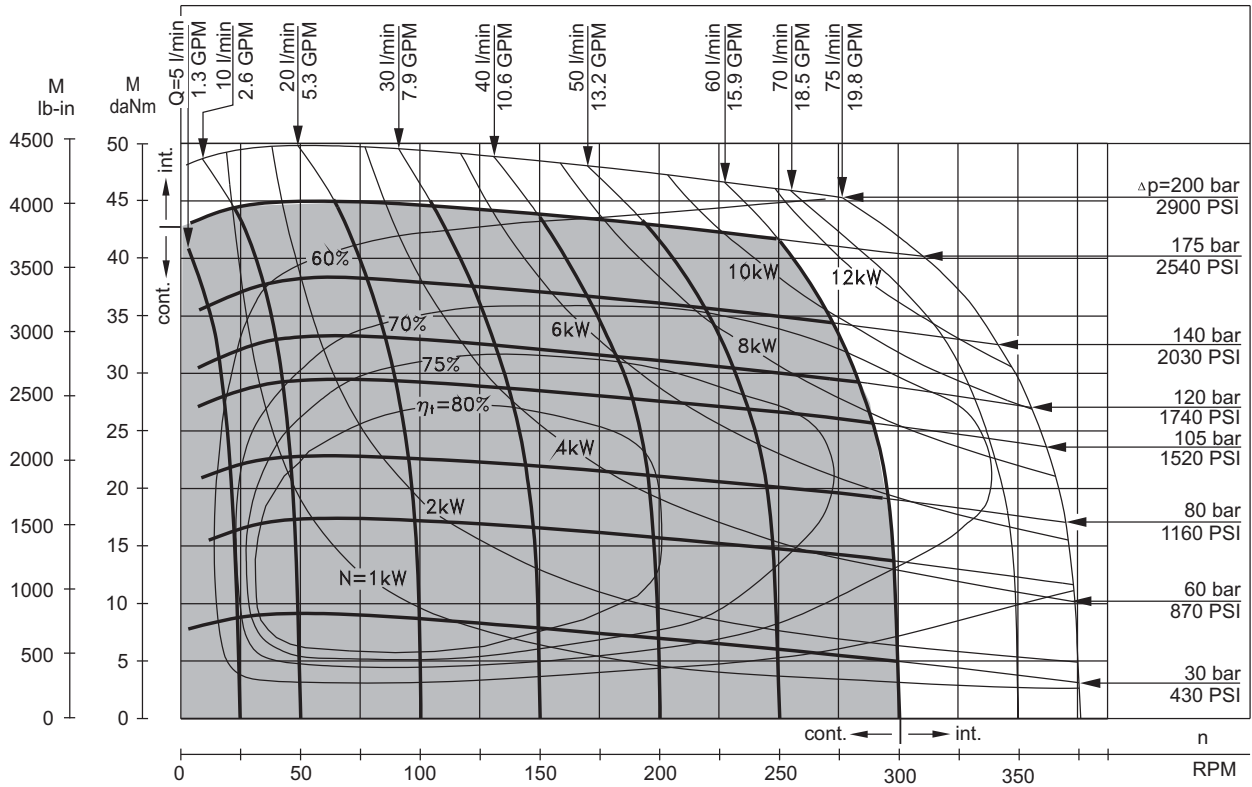

The function diagrams data is for average performance of randomly selected motors at back pressure  $5 \pm 10$  bar [72.5±145 PSI] and oil with viscosity of  $32 \text{ mm}^2/\text{s}$  [150 SUS] at  $50^\circ\text{C}$  [122°F].



**FUNCTION DIAGRAMS**

**MR 400**

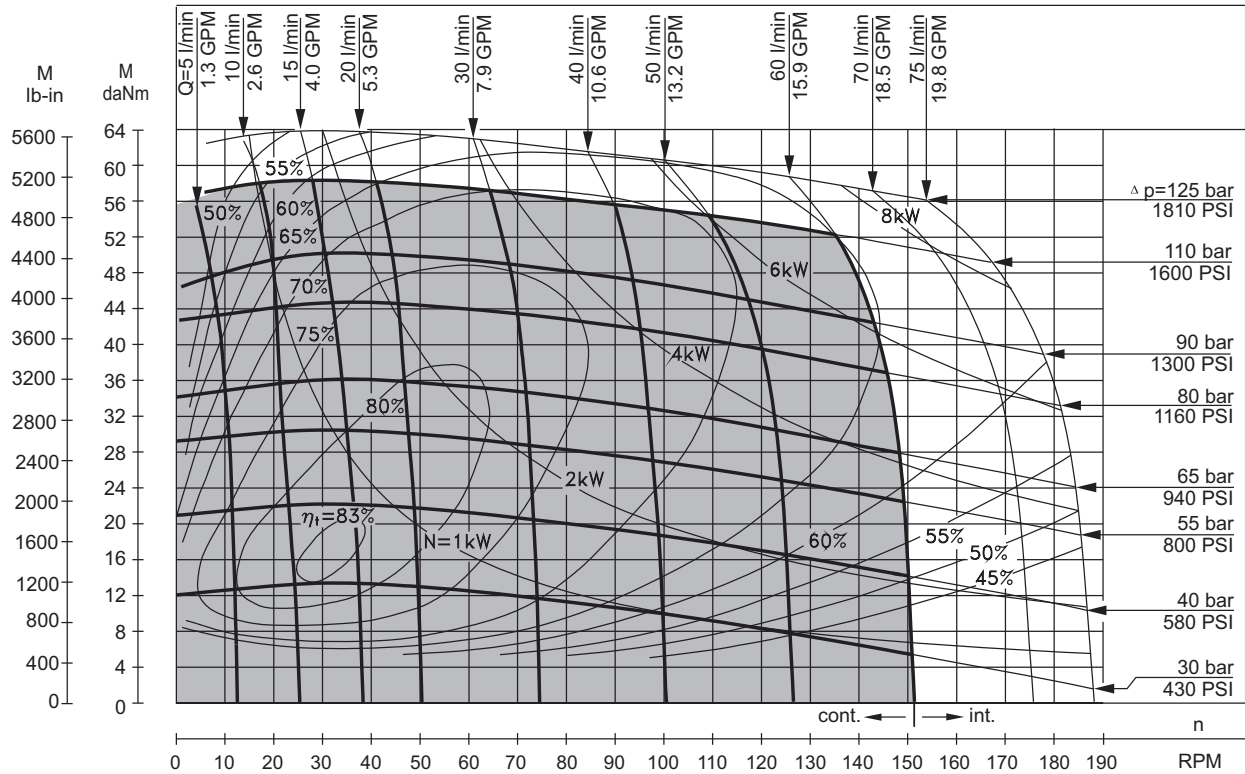

The function diagrams data is for average performance of randomly selected motors at back pressure  $5 \pm 10$  bar [72.5  $\pm$  145 PSI] and oil with viscosity of 32 mm<sup>2</sup>/s [150 SUS] at 50°C [122°F].



**DIMENSIONS AND MOUNTING DATA**

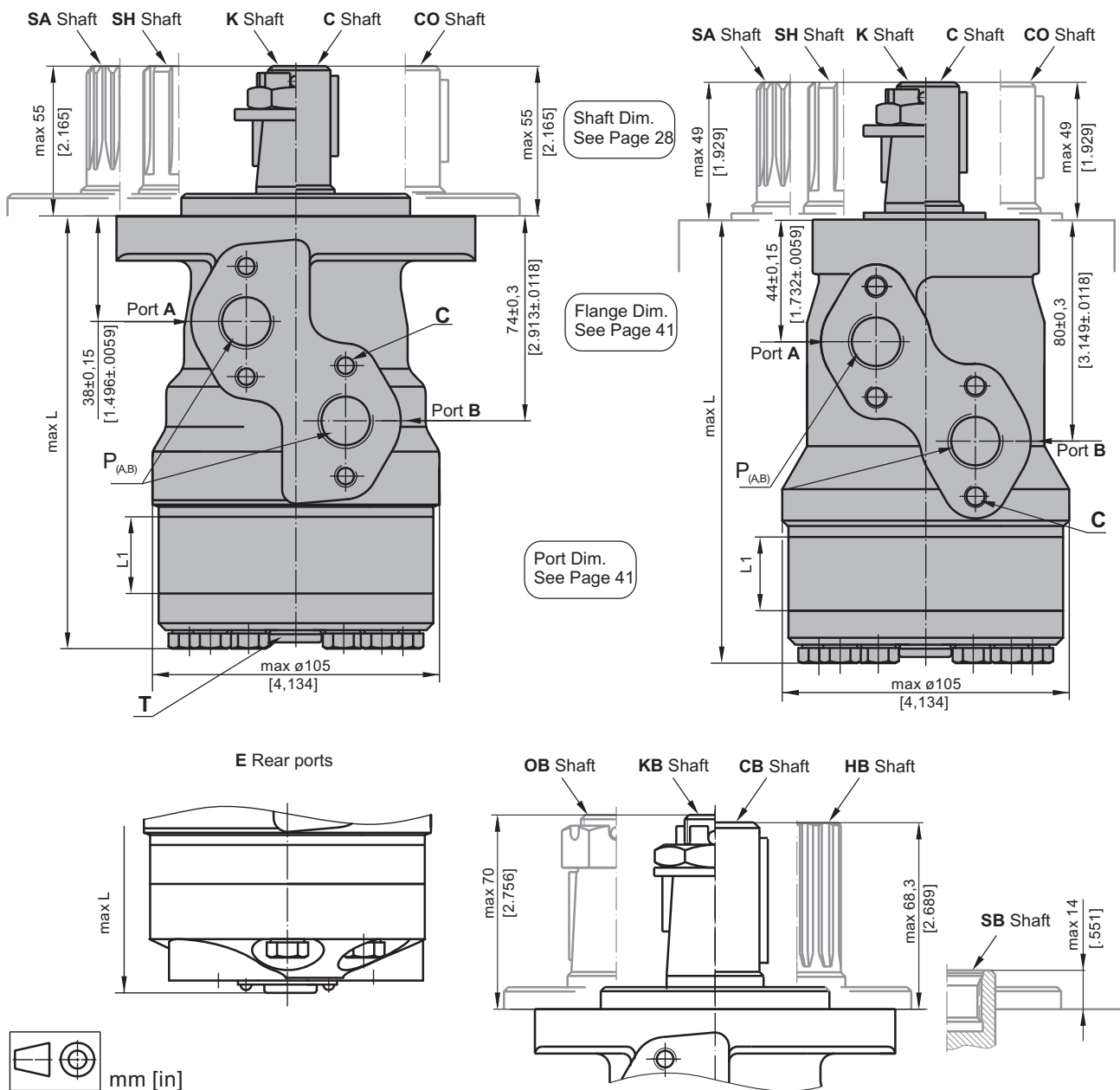

- C** : 4xM8 - 13 mm [.51 in] depth
- P<sub>(A,B)</sub>**: 2xG1/2 or 2xM22x1,5 - 15 mm [.59 in] depth
- T** : G1/4 or M14x1,5 - 12 mm [.47 in] depth (plugged)

- Standard Rotation**  
Viewed from Shaft End  
Port A Pressurized - CW  
Port B Pressurized - CCW
- Reverse Rotation**  
Viewed from Shaft End  
Port A Pressurized - CCW  
Port B Pressurized - CW

| Type      | L, mm [in]   | Type    | L, mm [in]   | Type       | L, mm [in]   | Type     | L, mm [in]   | L <sub>1</sub> , mm [in] |
|-----------|--------------|---------|--------------|------------|--------------|----------|--------------|--------------------------|
| MR(F) 50  | 138,0 [5.43] | MRQ 50  | 143,5 [5.65] | MR(F)E 50  | 157,5 [6.20] | MRQE 50  | 163,5 [6.44] | 9,0 [.35]                |
| MR(F) 80  | 143,0 [5.63] | MRQ 80  | 148,5 [5.85] | MR(F)E 80  | 162,5 [6.40] | MRQE 80  | 168,5 [6.63] | 14,0 [.55]               |
| MR(F) 100 | 146,0 [5.75] | MRQ 100 | 152,0 [5.98] | MR(F)E 100 | 165,5 [6.52] | MRQE 100 | 171,5 [6.75] | 17,4 [.69]               |
| MR(F) 125 | 150,5 [5.93] | MRQ 125 | 156,5 [6.16] | MR(F)E 125 | 170,0 [6.69] | MRQE 125 | 176,0 [6.93] | 21,8 [.86]               |
| MR(F) 160 | 156,5 [6.16] | MRQ 160 | 162,5 [6.40] | MR(F)E 160 | 176,0 [6.93] | MRQE 160 | 182,0 [7.17] | 27,8 [1.09]              |
| MR(F) 200 | 163,5 [6.44] | MRQ 200 | 169,5 [6.67] | MR(F)E 200 | 183,0 [7.20] | MRQE 200 | 189,0 [7.44] | 34,8 [1.37]              |
| MR(F) 250 | 172,0 [6.77] | MRQ 250 | 179,0 [7.05] | MR(F)E 250 | 192,0 [7.56] | MRQE 250 | 198,0 [7.80] | 43,5 [1.71]              |
| MR(F) 315 | 183,0 [7.20] | MRQ 315 | 189,0 [7.44] | MR(F)E 315 | 204,0 [8.03] | MRQE 315 | 210,0 [8.27] | 54,8 [2.16]              |
| MR(F) 400 | 198,0 [7.80] | MRQ 400 | 204,0 [8.03] | MR(F)E 400 | 218,0 [8.58] | MRQE 400 | 224,0 [8.82] | 69,4 [2.73]              |

**MOUNTING**

Oval Mount (2 Holes)

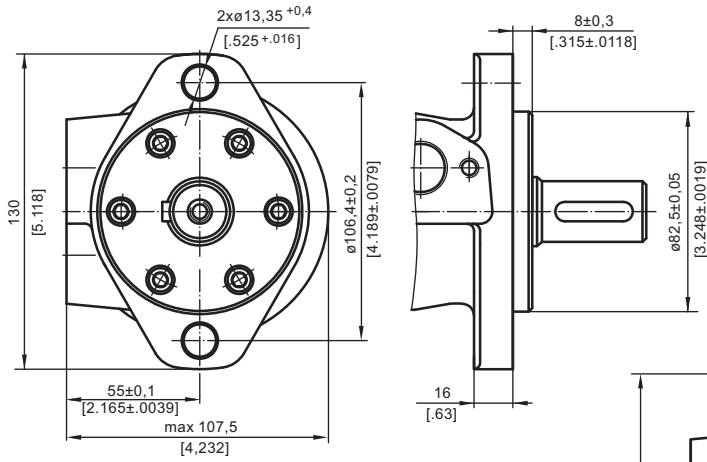

**F** - Oval Mount (4 Holes)

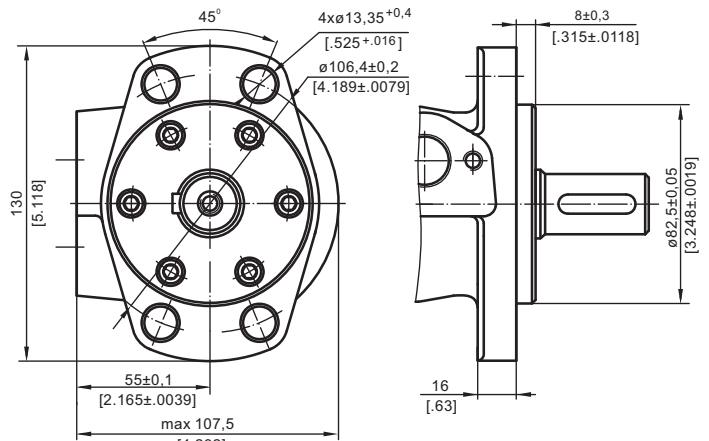

**Q** - Square Mount (4 Bolts)

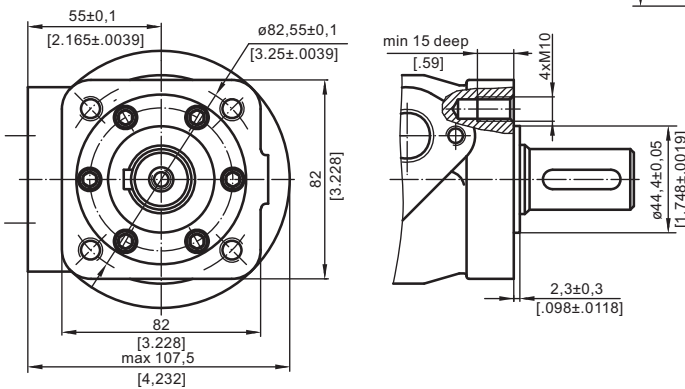

**PORTS**

Side Ports

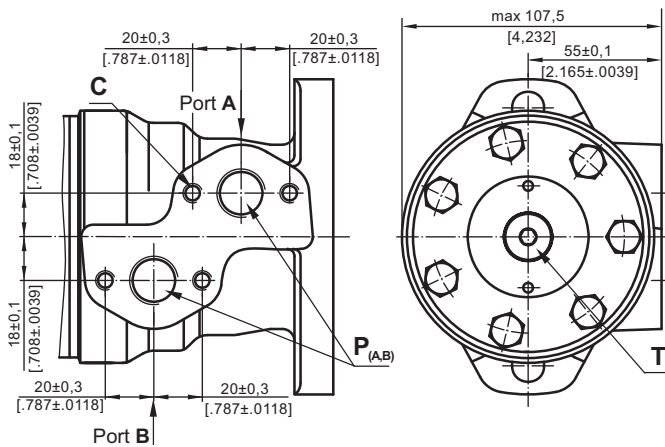

**E** Rear Ports

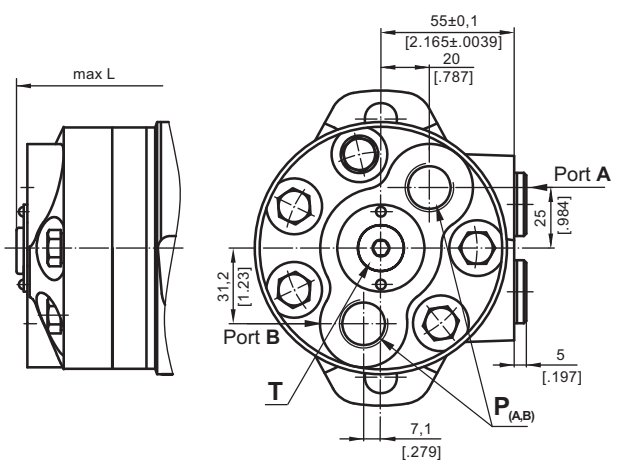

- C** : 4xM8 - 13 mm [.51 in] depth
- P<sub>(A,B)</sub>** : 2xG1/2 or 2xM22x1,5 - 15 mm [.59 in] depth
- T** : G1/4 or M14x1,5 - 12 mm [.47 in] depth (plugged)

**Standard Rotation**  
Viewed from Shaft End  
Port A Pressurized - CW  
Port B Pressurized - CCW

**Reverse Rotation**  
Viewed from Shaft End  
Port A Pressurized - CCW  
Port B Pressurized - CW

**ORDER CODE**

|            |   |   |   |   |   |   |   |   |   |    |
|------------|---|---|---|---|---|---|---|---|---|----|
|            | 1 | 2 | 3 | 4 | 5 | 6 | 7 | 8 | 9 | 10 |
| <b>M R</b> |   |   |   |   |   |   |   |   |   |    |

**Pos.1 - Mounting Flange**

- omit - Oval mount, two holes
- F** - Oval mount, four holes
- Q** - Square mount, four bolts

**Pos.2 - Option (needle bearings)**

- omit - none
- N** - with needle bearings

**Pos.3 - Port type**

- omit - Side ports
- E** - Rear ports

**Pos.4 - Displacement code**

- 50** - 51,5 cm<sup>3</sup>/rev [ 3.14 in<sup>3</sup>/rev]
- 80** - 80,3 cm<sup>3</sup>/rev [ 4.90 in<sup>3</sup>/rev]
- 100** - 99,8 cm<sup>3</sup>/rev [ 6.09 in<sup>3</sup>/rev]
- 125** - 125,7 cm<sup>3</sup>/rev [ 7.67 in<sup>3</sup>/rev]
- 160** - 159,6 cm<sup>3</sup>/rev [ 9.74 in<sup>3</sup>/rev]
- 200** - 199,8 cm<sup>3</sup>/rev [12.19 in<sup>3</sup>/rev]
- 250** - 250,1 cm<sup>3</sup>/rev [15.26 in<sup>3</sup>/rev]
- 315** - 315,7 cm<sup>3</sup>/rev [19.26 in<sup>3</sup>/rev]
- 400** - 397,0 cm<sup>3</sup>/rev [24.40 in<sup>3</sup>/rev]

**Pos.5 - Shaft Extensions\*(see page 28)**

- C** - ø25 straight, Parallel key A8x7x32 DIN6885
- VC** - ø25 straight, Parallel key A8x7x32 DIN6885 with corrosion resistant bushing
- CO** - ø1" straight, Parallel key ¼"x¼"x1¼" BS46
- VCO** - ø1" straight, Parallel key ¼"x¼"x1¼" BS46 with corrosion resistant bushing
- SH** - ø25,32 splined BS 2059 (SAE 6B)
- VSH** - ø25,32 splined BS 2059 (SAE 6B) with corrosion resistant bushing
- K** - ø28,56 tapered 1:10, Parallel key B5x5x14 DIN6885
- SA** - ø24,5 splined B 25x22 DIN 5482
- VSA** - ø24,5 splined B 25x22 DIN 5482 with corrosion resistant bushing
- CB** - ø32 straight, Parallel key A10x8x45 DIN6885
- KB** - ø35 tapered 1:10, Parallel key B6x6x20 DIN6885
- SB** - splined A 25x22 DIN 5482
- OB** - ø1¼" tapered 1:8, Parallel key ⅜"x⅜"x1¼" BS46
- HB** - ø1¼" splined 14T ANSI B92.1 - 1976

**Pos. 6 - Shaft Seal Version (see page 30)**

- omit - Low pressure shaft seal or Standard shaft seal for "...B" shaft
- D** - Standard shaft seal
- U** - High pressure shaft seal (without check valves)

**Pos. 7 - Drain Port**

- omit - with drain port
- 1** - without drain port

**Pos. 8 - Ports**

- omit - BSPP (ISO 228)
- M** - Metric (ISO 262)

**Pos. 9 - Special Features (see page 118)**

**Pos.10 - Design Series**

- omit - Factory specified

**NOTES:**

- The following combinations are not allowed:
- **Q** flange with "...B" shafts;
  - **N** option with "...B" shafts, Low Pressure Seal or **U** option;
  - "...B" shafts with **D** and **U** shaft seals.

\* The permissible output torque for shafts must not be exceeded!  
The hydraulic motors are mangano-phosphatized as standard.

# Hydraulic motors type MR...T with tacho connection

MR motors are available in version with tacho drive shaft. With tacho connection the speed of the motor can be registered. Tacho shaft has a 6 times higher revolution speed than output shaft and opposite direction of rotation.

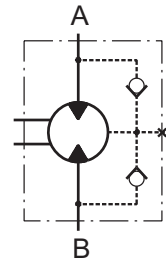

## OUTLINE DIMENSIONS REFERENCE

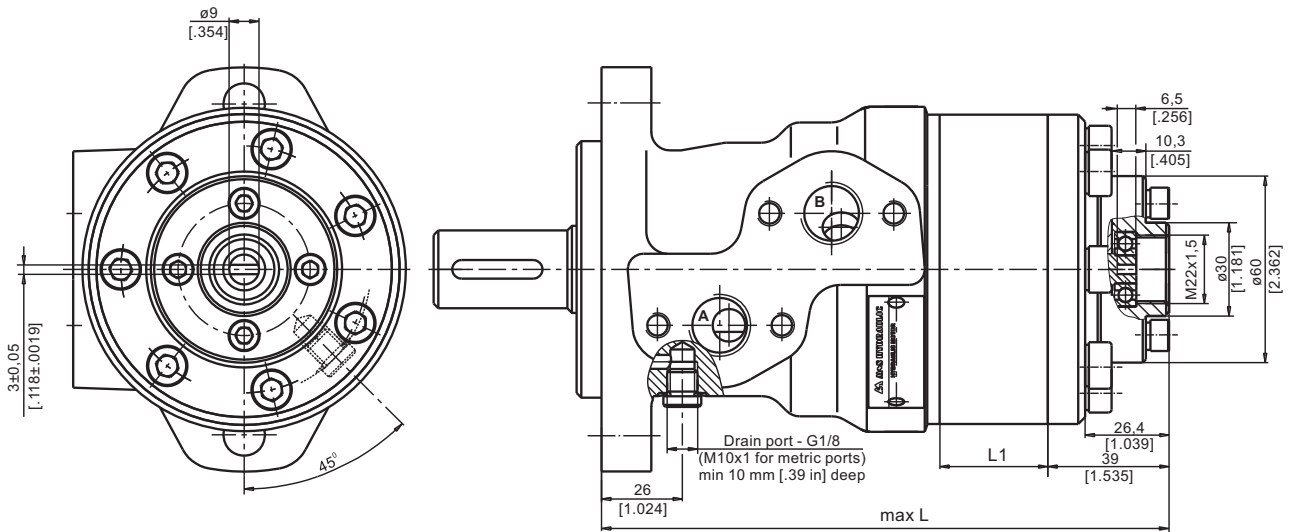

| Type   | L, mm [in] | L <sub>t</sub> , mm [in] |
|--------|------------|--------------------------|
| MR 50  | 157 [6.18] | 9,0 [.35]                |
| MR 80  | 162 [6.38] | 14,0 [.55]               |
| MR 100 | 165 [6.50] | 17,4 [.69]               |
| MR 125 | 170 [6.69] | 21,8 [.86]               |
| MR 160 | 176 [6.93] | 27,8 [1.09]              |
| MR 200 | 183 [7.20] | 34,8 [1.37]              |
| MR 250 | 192 [7.56] | 43,5 [1.71]              |
| MR 315 | 204 [8.03] | 54,8 [2.16]              |
| MR 400 | 218 [8.58] | 69,4 [2.73]              |



### Notes:

Radial or axial load on tacho shaft must be avoided. Max. torque on tacho shaft 0,1 daNm [.885 lb-in].  
Max. cont. return pressure without drain line 20 bar [290 PSI].

Tacho option for MR motor is available only for shafts with sealing diameter  $\varnothing 28,56$  with shaft seal type **D** (up to 150 bar).

It is not allowed for Q-flange.

The main technical features correspond to the standard motors series MR. There are no changes in the overall and mounting dimensions. For detail technical and mounting data please refer to MR catalogue.